

# 10-W Inductor Free Stereo Audio Amplifier with Low EMI and AGC

## DESCRIPTION

The EUA2385A is a high efficiency 2 channel bridged-tied load (BTL) Class-D audio power amplifier, driving stereo speakers at up to 10W/CH with 6Ω or 8Ω Load. The EUA2385A features a differential input architecture offering improved noise immunity over a single-ended (SE) input amplifier.

Advanced EMI Suppression Technology with Spread Spectrum Control enables the use of inexpensive ferrite bead filters at the outputs while meeting EMC requirements for system cost reduction.

EUA2385A is not only fully protected against shorts and overload, an adjustable Auto Gain Control and a DC detection circuit for protection of the connected speakers. The DC detect and Pin-to-Pin, Pin-to-Ground and Pin-to-Power Short Circuit protection circuit protect the speakers from output DC and pin shorts caused in production. The short circuit protection and thermal protection includes an auto recovery feature.

EUA2385A is available in thermally efficient 28-pin TSSOP package and will be able to output full power on a 2-layer PCB.

## FEATURES

- Wide Supply Voltage: 4.5V to 16V
- Enhanced Modulation Scheme Reduces EMI Emission
- 10-W/ch into an 6-Ω Load From a 12-V Supply
- 10-W/ch into an 8-Ω Load From a 13-V Supply
- Differential Inputs or Single-Ended input
- Speaker Protection Circuitry
- Four Selectable, Gain Setting
- Auto Gain Control Function(AGC )
- Thermal and Short-Circuit Protection
- 28-pin TSSOP Package with Thermal Pad
- RoHS compliant and 100% lead(Pb)-free Halogen-Free

## APPLICATIONS

- Televisions
- USB Speaker
- Mini Speaker
- Consumer Audio Equipment

## Typical Application Circuit

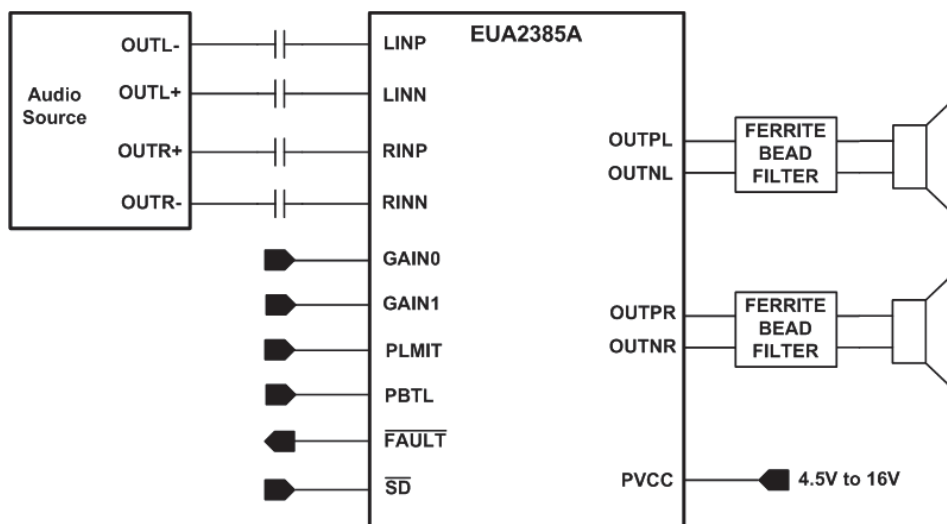

Figure1. Simplified Application Schematic