

60V, 3A, Asynchronous Step-Down Converter with Programmable Frequency

DESCRIPTION

The EUP3253 is a 60V, 3A, step down regulator with an integrated high side MOSFET. The EUP3253 adopting the peak current mode control, supports the PSM mode which assists the converter on achieving high efficiency at light load or standby condition.

The EUP3253 features programmable switching frequency from 100 kHz to 2MHz with an external resistor, which provides the flexibility to optimize either efficiency or external component size. The converter supports external clock synchronization with a frequency band from 160 kHz to 2MHz. The EUP3253 allows power conversion from high input voltage to low output voltage with a minimum 130ns on-time of high-side MOSFET.

Fault protection includes secondary cycle-by-cycle current limit, short circuit protection and thermal shutdown. Internal soft-start minimizes the inrush supply current and the output overshoot at initial startup.

The EUP3253 is available in an 8-pin SOP-8(EP) package.

FEATURES

- Wide Input Voltage Range: 4.5V to 60V
- High Efficiency at Light Loads with PSM Mode
- 150 μ A Operating Quiescent Current
- 3 μ A Shutdown Current
- 100kHz to 2MHz Fixed Switching Frequency
- Synchronizes to External Clock
- Adjustable UVLO Voltage and Hysteresis
- 0.8V 1% Internal Voltage Reference
- Internal Soft-start
- Short Circuit Protection
- Thermal Shutdown
- SOP-8(EP) Package

APPLICATIONS

- Vehicle Accessories : GPS, Entertainment
- 12-V, 24-V, 48-V Industrial, Automotive and Communications Power Systems
- USB Dedicated Charging Ports and Battery Chargers

Typical Application Circuit

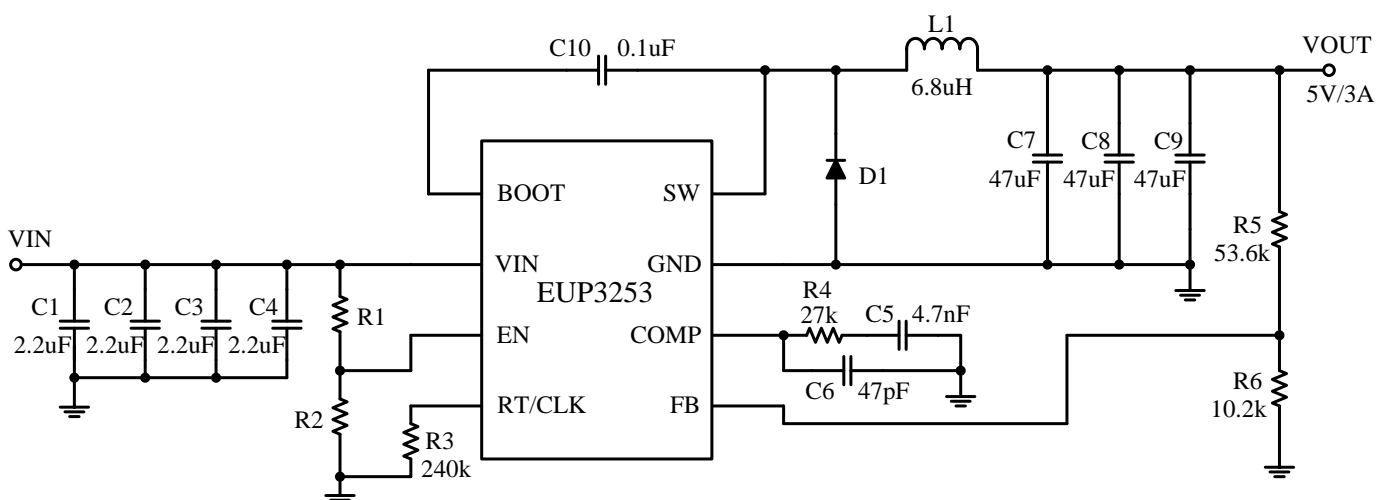

Figure 1. Application Circuit